

1 Why can ultrasound **not** be heard by humans?

- A The amplitude is too great.
- B The frequency is too great.
- C The speed is too great.
- D The wavelength is too great.

2 A sound wave has a certain amplitude and a certain frequency.

A second sound wave is quieter and lower in pitch than the first sound wave.

The second wave has

- A a larger amplitude and a greater frequency.
- B a larger amplitude and a smaller frequency.
- C a smaller amplitude and a greater frequency.
- D a smaller amplitude and a smaller frequency.

3 What is the approximate range of hearing of a healthy human ear?

- A 2.0 Hz to 2.0 kHz
- B 2.0 Hz to 20 kHz
- C 20 Hz to 2.0 kHz
- D 20 Hz to 20 kHz

4 A singer sings two notes. The first note is louder and lower in pitch than the second note.

Which statement about the two notes is correct?

- A The first note has a larger amplitude and a larger frequency than the second note.
- B The first note has a larger amplitude and a smaller frequency than the second note.
- C The first note has a smaller amplitude and a larger frequency than the second note.
- D The first note has a smaller amplitude and a smaller frequency than the second note.

5 Which range of wave frequencies includes only sounds that can be heard by a human with normal hearing?

- A 3.0 Hz to 300 Hz
- B 30 Hz to 3000 Hz
- C 300 Hz to 30 000 Hz
- D 3000 Hz to 300 000 Hz

6 A candle flame is placed in front of a loudspeaker.

The loudspeaker produces a sound wave that causes air particles to vibrate. The vibrating air particles make the candle flame vibrate in the same direction as the air particles.

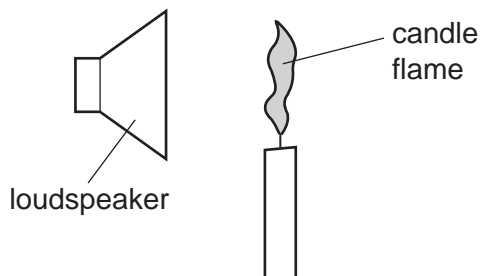

Which row shows the direction of vibration of the candle flame, and the nature of sound waves?

	direction of vibration	nature of sound waves
A	↕	longitudinal
B	↕	transverse
C	↔	longitudinal
D	↔	transverse

7 A sound wave travels from a point X to another point Y.

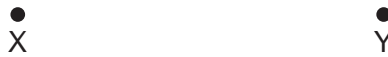

Which diagram represents the movement of the air molecules, due to the sound wave, in the region between X and Y?



8 Sound wave P has a greater amplitude and a larger wavelength in air than sound wave Q.

How do the loudness and pitch of P compare with the loudness and pitch of Q?

- A P is louder and higher in pitch than Q.
- B P is louder and lower in pitch than Q.
- C P is quieter and higher in pitch than Q.
- D P is quieter and lower in pitch than Q.

9 An echo-sounder on a ship produces a pulse of sound. The echo is received by the echo-sounder after two seconds.

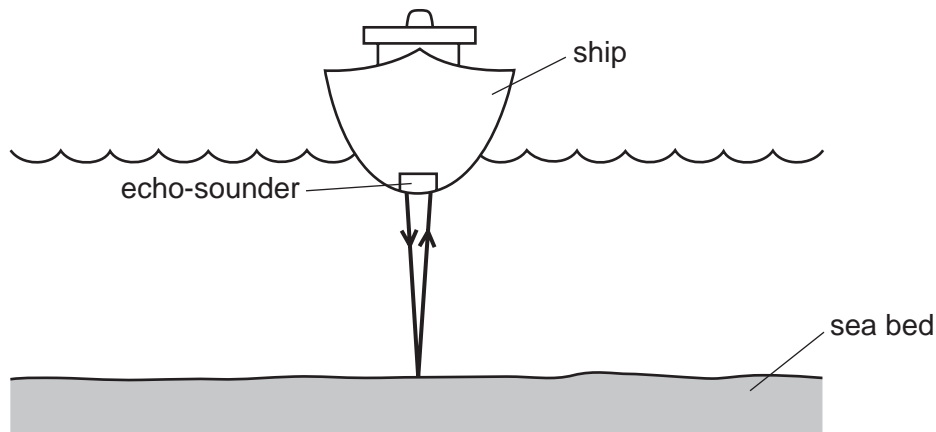

The speed of sound in sea-water is 1500 m/s.

What is the depth of the sea-water below the ship?

- A 750 m
- B 1500 m
- C 3000 m
- D 6000 m

10 Which frequency produces a sound that can be heard by a person?

- A 2 Hz
- B 10 Hz
- C 2 kHz
- D 30 kHz

- 11 A scientist tries to direct a ray of light in a glass block so that no light escapes from the top of the block.

However, some light does escape.

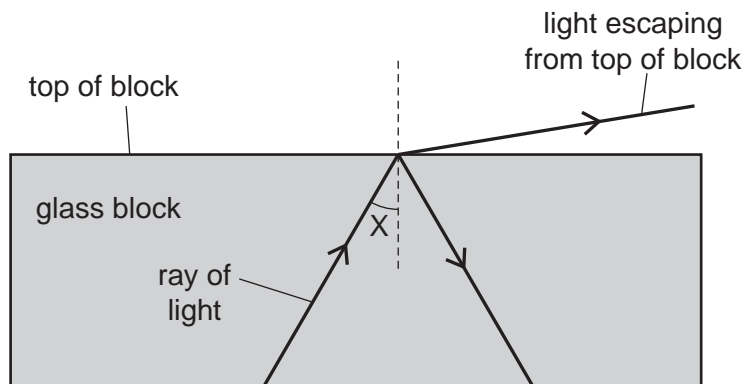

The scientist changes angle X and stops the light escaping from the top.

Which row in the table describes the change to angle X and the name of the effect produced?

	change to angle X	name of effect produced
A	decrease	total internal reflection
B	decrease	total internal refraction
C	increase	total internal reflection
D	increase	total internal refraction

- 12 Which row states two properties of sound waves?

	can travel through	type of wave
A	a vacuum	longitudinal
B	a vacuum	transverse
C	water	longitudinal
D	water	transverse

13 A quiet sound is produced by a loudspeaker. The loudness of the sound is increased.

Which property of the sound wave is increased?

- A amplitude
- B frequency
- C speed
- D wavelength

14 A man holding a starting pistol stands 640 m away from a spectator.

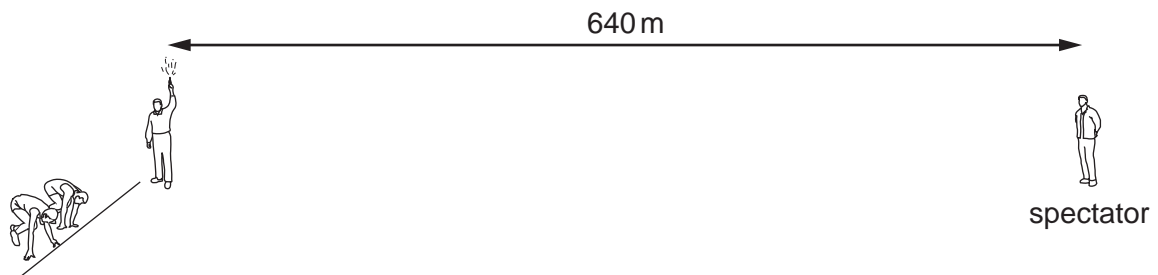

The spectator hears the sound of the starting pistol 2.0 s after seeing the flash from the pistol.

Using this information, what is the speed of sound in air?

- A 160 m/s
- B 320 m/s
- C 640 m/s
- D 1280 m/s

15 The frequency of a musical note is increased.

A student hearing the sound detects an increase in which property?

- A loudness of the sound
- B pitch of the sound
- C speed of the sound wave
- D wavelength of the sound wave

- 16 In the experiment shown, the bell is heard ringing. The air is gradually pumped out of the jar. No change is made to the ringing bell.

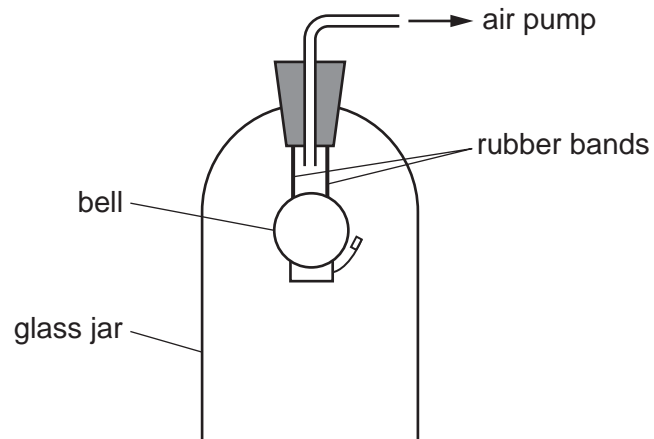

After a few minutes the bell can no longer be heard.

Why is this?

- A** The amplitude of vibration of the bell decreases.
- B** The frequency of vibration of the bell increases.
- C** The sound waves from the bell become transverse.
- D** The sound waves need a medium to travel through.

17 What can be heard by the human ear?

- A a whistle emitting a wave of frequency 50 kHz
- B a bat emitting a wave of frequency 30 kHz
- C an insect emitting a wave of frequency 300 Hz
- D a vibrating spring emitting a wave of frequency 5 Hz

18 Which row states whether light waves and whether sound waves can travel in a vacuum?

	sound waves	light waves
A	no	no
B	no	yes
C	yes	no
D	yes	yes

19 Sounds are produced by vibrating objects. A certain object vibrates but a person nearby cannot hear any sound.

Which statement could explain why nothing is heard?

- A The amplitude of the sound waves is too large.
- B The frequency of the vibration is too high.
- C The sound waves are transverse.
- D The speed of the sound waves is too high.

20 Two sounds X and Y are produced by loudspeakers.

The amplitude and frequency of each sound wave is given in the table.

	amplitude/mm	frequency/Hz
X	1.3	475
Y	2.0	235

How does sound Y compare with sound X?

- A Y is louder and has a higher pitch.
 - B Y is louder and has a lower pitch.
 - C Y is quieter and has a higher pitch.
 - D Y is quieter and has a lower pitch.
- 21 A pulse of sound is produced at the bottom of a boat. The sound travels through the water and is reflected from the sea bed. The sound reaches the boat again after 1.2s. The speed of sound in the water is 1500 m/s.

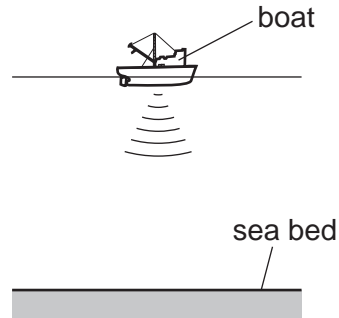

How far below the bottom of the boat is the sea bed?

- A 450 m
 - B 900 m
 - C 1800 m
 - D 3600 m
- 22 What is the approximate range of audible sound frequencies for a human with good hearing?
- A from 20 Hz to 2000 Hz
 - B from 20 Hz to 20 000 Hz
 - C from 200 Hz to 20 000 Hz
 - D from 200 Hz to 200 000 Hz

23 A boy blows a whistle that has a frequency of 10 000 Hz. The boy's friend cannot hear the sound from the whistle. The friend has normal hearing.

What could be a reason why he cannot hear the sound?

- A** The amplitude is too large.
- B** The amplitude is too small.
- C** The frequency is too high.
- D** The frequency is too low.

24 A lighted candle is placed in front of a loudspeaker that is making a loud, steady note. The candle flame vibrates because of the sound wave.

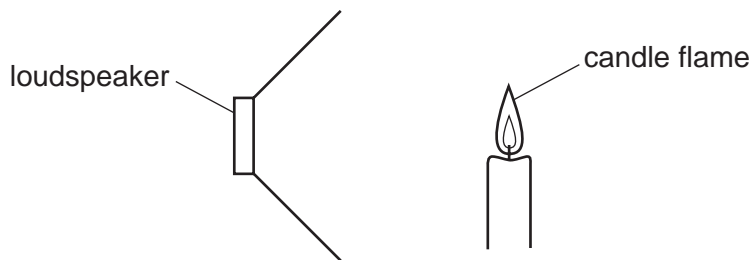

Which type of waves are sound waves and in which direction does the flame vibrate?

	type of wave	direction of vibration
A	longitudinal	
B	transverse	
C	longitudinal	
D	transverse	

25 The diagrams show the wave patterns of four sounds shown on a cathode-ray oscilloscope (c.r.o.). The oscilloscope controls are set the same for each sound.

Which sound has the highest pitch?

A

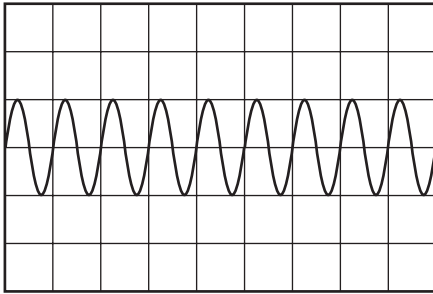

B

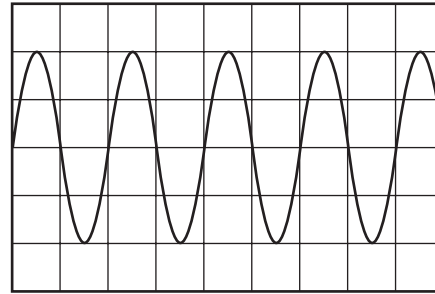

C

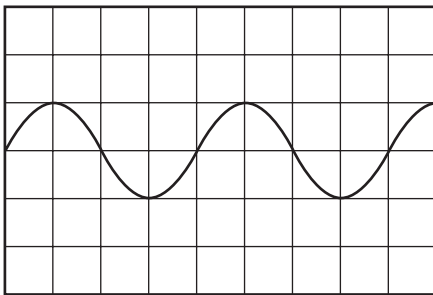

D

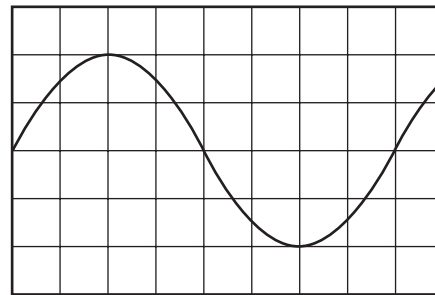

- 26 A fire alarm is not loud enough and the pitch is too low. An engineer adjusts the alarm so that it produces a louder note of a higher pitch.

What effect does this have on the amplitude and on the frequency of the sound waves that the alarm produces?

	amplitude	frequency
A	larger	larger
B	larger	smaller
C	smaller	larger
D	smaller	smaller

- 27 In an experiment to measure the speed of sound, a student uses a stopwatch to find the time taken for a sound wave to travel from X to Y. She does this six times.

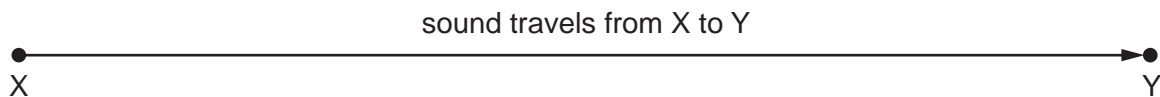

The table shows her results.

measurement	time / s
first	0.5
second	0.7
third	0.6
fourth	0.4
fifth	0.9
sixth	0.5

Which value for the time should be used to calculate the speed of sound?

- A** 0.4 s **B** 0.5 s **C** 0.6 s **D** 0.9 s

- 28 A fire alarm is not loud enough and the pitch is too low. An engineer adjusts the alarm so that it produces a louder note of a higher pitch.

What effect does this have on the amplitude and on the frequency of the sound waves that the alarm produces?

	amplitude	frequency
A	larger	larger
B	larger	smaller
C	smaller	larger
D	smaller	smaller

- 29 Three vibrating objects P, Q and R produce waves in the air of different frequencies as shown.

object	frequency/Hz
P	25
Q	1000
R	15000

Which of these waves can be heard by a human ear?

- A** P, Q and R
- B** P and Q only
- C** P and R only
- D** Q and R only

30 The diagrams represent two sound waves. The scales in the two diagrams are the same.

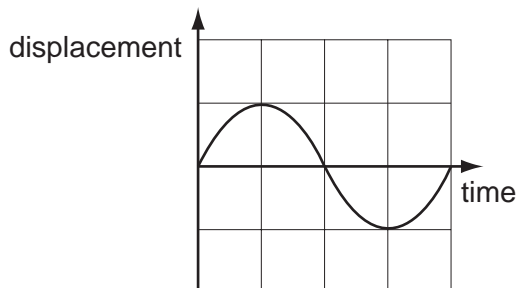

sound wave 1

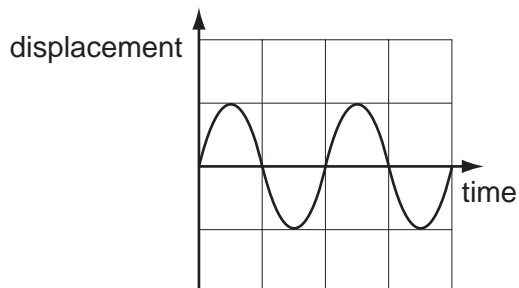

sound wave 2

Which statement describes the waves?

- A** The waves have different loudness and different pitch.
- B** The waves have different loudness but the same pitch.
- C** The waves have the same loudness and the same pitch.
- D** The waves have the same loudness but different pitch.

31 A student claps once when standing 100 m away from a large wall.

The speed of sound in air is 330 m/s.

How long after clapping does the student hear an echo?

- A** 0.30 s **B** 0.61 s **C** 1.7 s **D** 3.3 s

32 A tuning fork is marked with the number 320.

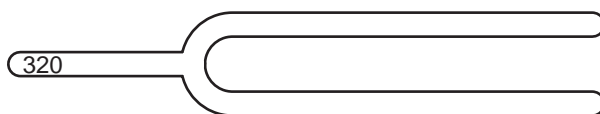

This indicates the size of the frequency.

What does this mean?

- A The length of the tuning fork is 320 mm.
- B The note from the tuning fork will last for up to 320 s.
- C The sound waves produced by the tuning fork travel at 320 m/s.
- D The tuning fork vibrates 320 times every second.

33 Some sound from a loudspeaker at P travels directly to Q. Sound also reaches Q after being reflected from a wall at R.

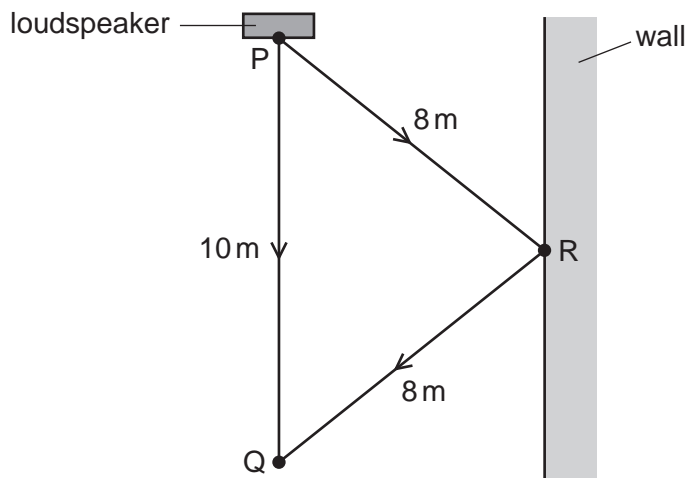

The speed of sound is 330 m/s.

What is the **difference** in time for a sound to travel from P to Q by the two routes?

- A $\left(\frac{6}{330}\right)$ s
- B $\left(\frac{16}{330}\right)$ s
- C (6×330) s
- D (16×330) s

34 The diagrams represent two sound waves. The scales in the two diagrams are the same.

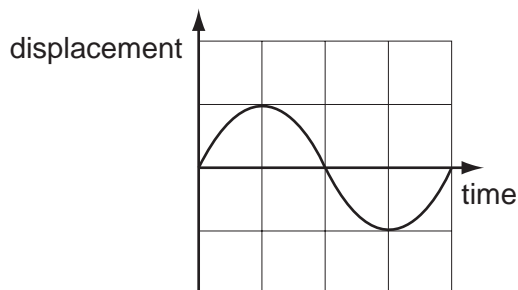

sound wave 1

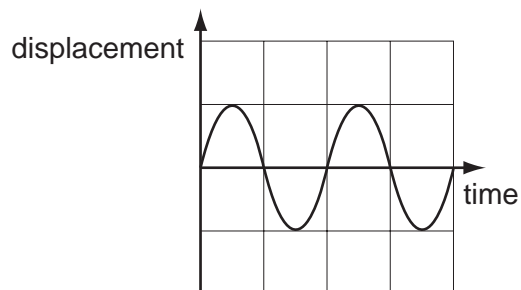

sound wave 2

Which statement describes the waves?

- A The waves have different loudness and different pitch.
- B The waves have different loudness but the same pitch.
- C The waves have the same loudness and the same pitch.
- D The waves have the same loudness but different pitch.

35 When the volcano Krakatoa erupted in 1883, it was heard 5000 km away.

Which statement about the sound from the volcano is **not** correct?

- A If such a loud sound were to be made today, an astronaut orbiting in space (a vacuum) at a height of 400 km could hear it.
- B People further from the volcano heard the sound later than people nearer to the volcano.
- C The amplitude of the sound waves would have been smaller further from the volcano.
- D The sound was very loud because a lot of energy was transferred to vibrations of the air.

- 36 A loudspeaker on a boat produces a pulse of sound in the sea. The echo of the pulse is received back at the boat after 3.0 s. The depth of the sea under the boat is 2250 m.

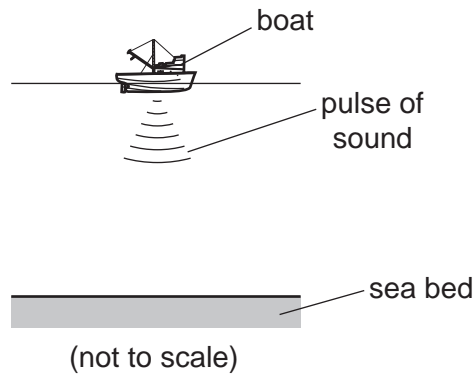

From this information, what is the speed of sound in the sea water?

- A** 330 m/s **B** 750 m/s **C** 1500 m/s **D** 6750 m/s
- 37 To estimate the width of a valley, a climber starts a stopwatch as he shouts. He hears an echo from the opposite side of the valley after 1.0 s.

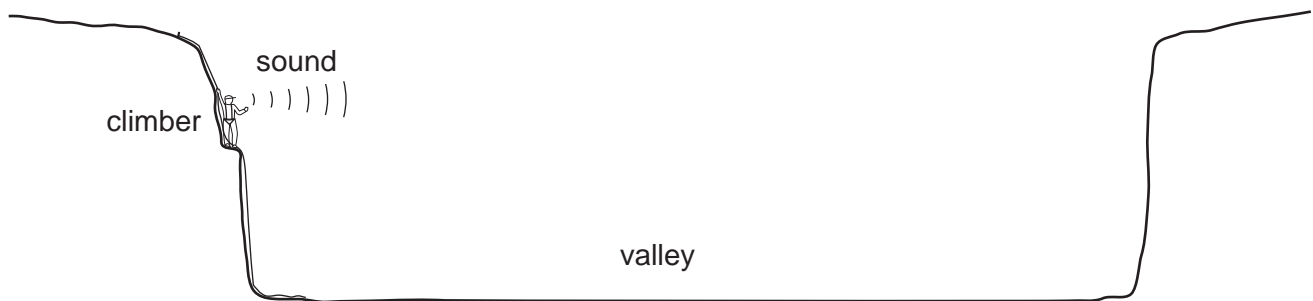

The sound travels at 330 m/s.

What is the width of the valley?

- A** 82.5 m **B** 165 m **C** 330 m **D** 660 m

- 38 A police car sounds its siren when travelling to an emergency. The siren produces two different sounds P and Q, which are emitted alternately.

The diagram represents the sound waves emitted by the siren.

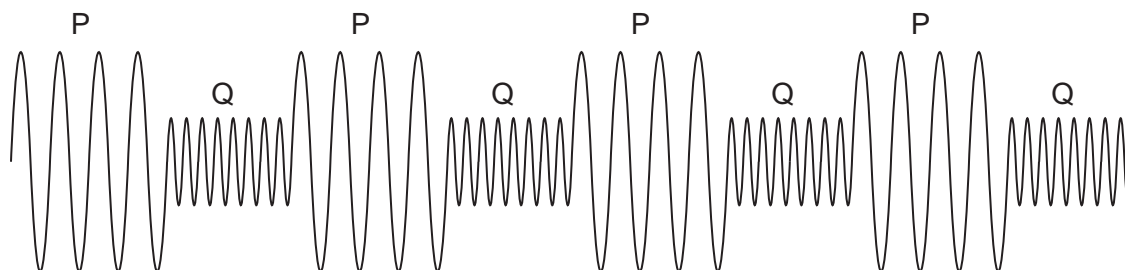

Which of the two sounds P and Q is the louder and which has the higher pitch?

	louder sound	sound of higher pitch
A	P	P
B	P	Q
C	Q	P
D	Q	Q

- 39 A girl stands at a distance from a large building. She claps her hands and a short time later hears an echo.

Why is an echo produced when the sound waves hit the building?

- A** The sound waves are absorbed.
- B** The sound waves are diffracted.
- C** The sound waves are reflected.
- D** The sound waves are refracted.

40 The diagrams represent the waves produced by four sources of sound. The scales are the same for all the diagrams.

Which sound has the highest frequency?

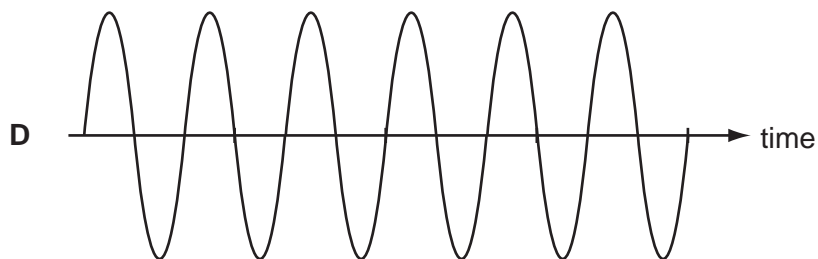
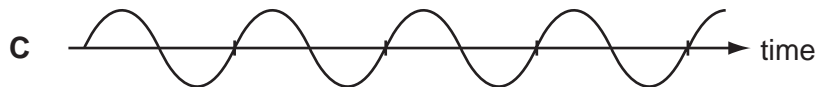
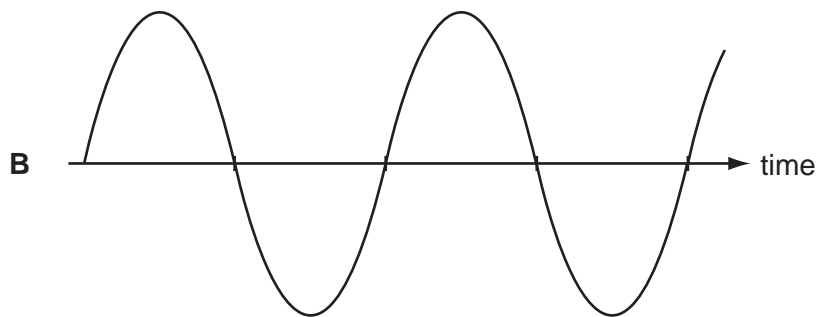
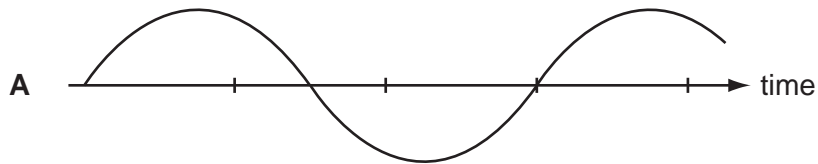

41 Three loudspeakers vibrate at different frequencies of 5 hertz, 25 kilohertz and 50 kilohertz.

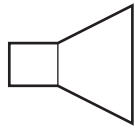

5 hertz

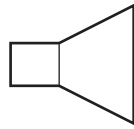

25 kilohertz

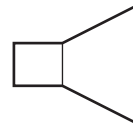

50 kilohertz

Which row shows whether the vibrations from each loudspeaker can be heard by a human?

	5 hertz	25 kilohertz	50 kilohertz
A	no	no	no
B	no	yes	no
C	yes	no	yes
D	yes	yes	yes

42 A tennis player hits a ball hard and 0.40 s later hears the echo from a wall.



The speed of sound in air is 330 m/s.

How far away is the player from the wall?

A 66 m

B 132 m

C 264 m

D 825 m

43 Sound travels by wave motion.

Which property of waves causes echoes?

- A diffraction
- B dispersion
- C reflection
- D refraction

44 A student listens to a machine that makes sounds of different frequencies. He can only hear one of the sounds.

Which frequency of sound is the student able to hear?

- A 2 Hz B 10 Hz C 2 kHz D 30 kHz

45 A student wishes to measure the speed of sound in air. She plans to measure the time between making a sound and hearing the echo from a cliff.



She will use the equation: $\text{speed} = \frac{\text{distance}}{\text{time}}$.

Which type of sound should she make and which distance should she use in her calculation?

	type of sound	distance to use
A	continuous sound	$\frac{\text{distance to cliff}}{2}$
B	continuous sound	distance to cliff \times 2
C	short, sharp sound	$\frac{\text{distance to cliff}}{2}$
D	short, sharp sound	distance to cliff \times 2

- 46 The diagrams show the wave shapes of two different sounds. The scales are the same in each diagram.

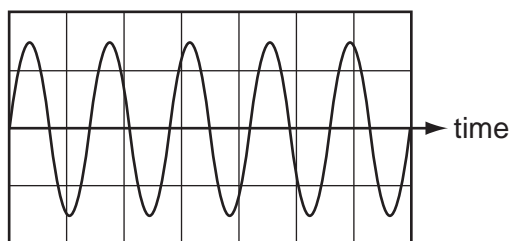

sound 1

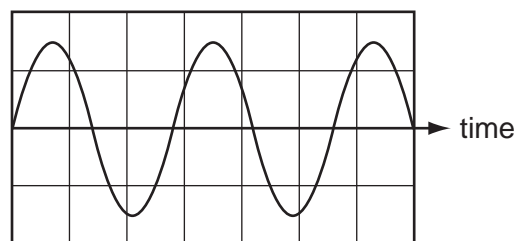

sound 2

How does sound 2 compare with sound 1?

- A** Sound 2 is louder than sound 1.
- B** Sound 2 is quieter than sound 1.
- C** Sound 2 has a higher pitch than sound 1.
- D** Sound 2 has a lower pitch than sound 1.

- 47 A sound wave travels through air as a series of compressions and rarefactions.

Which row correctly compares the air pressure in a compression and the air pressure in a rarefaction to the air pressure nearby where there is no sound wave?

	air pressure in a compression	air pressure in a rarefaction
A	higher	higher
B	higher	lower
C	lower	higher
D	lower	lower

48 A sound wave has a certain amplitude and a certain frequency.

A second sound wave is quieter and lower in pitch than the first sound wave.

The second wave has

- A a larger amplitude and a greater frequency.
- B a larger amplitude and a smaller frequency.
- C a smaller amplitude and a greater frequency.
- D a smaller amplitude and a smaller frequency.

49 The sound from a loudspeaker must pass through two materials to reach a microphone.

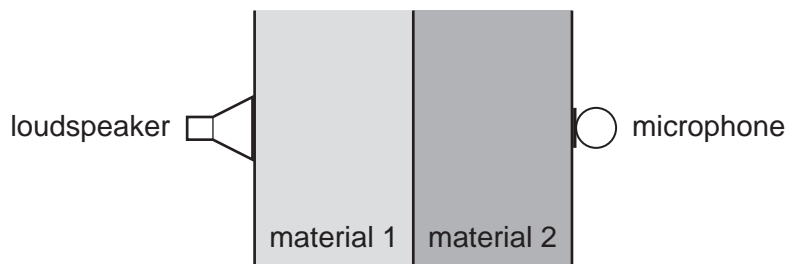

Which combination of materials gives the shortest time for the sound to reach the microphone?

	material 1	material 2
A	air	hydrogen
B	air	water
C	copper	aluminium
D	water	oil

50 Which range of wave frequencies includes only sounds that can be heard by a human with normal hearing?

- A 3.0 Hz to 300 Hz
- B 30 Hz to 3000 Hz
- C 300 Hz to 3000 Hz
- D 3000 Hz to 30000 Hz

51 A sound wave travels from a point X to a point Y.



Which diagram represents the movement of the air molecules, due to the sound wave, in the region between X and Y?



52 The speed of sound in air is 340 m/s.

Which row gives typical values for the speed of sound in a liquid and in a solid?

	speed of sound in a liquid / (m/s)	speed of sound in a solid / (m/s)
A	250	180
B	250	5000
C	1500	180
D	1500	5000

- 53 An echo-sounder on a ship produces a pulse of sound. The echo is received by the echo-sounder after two seconds.

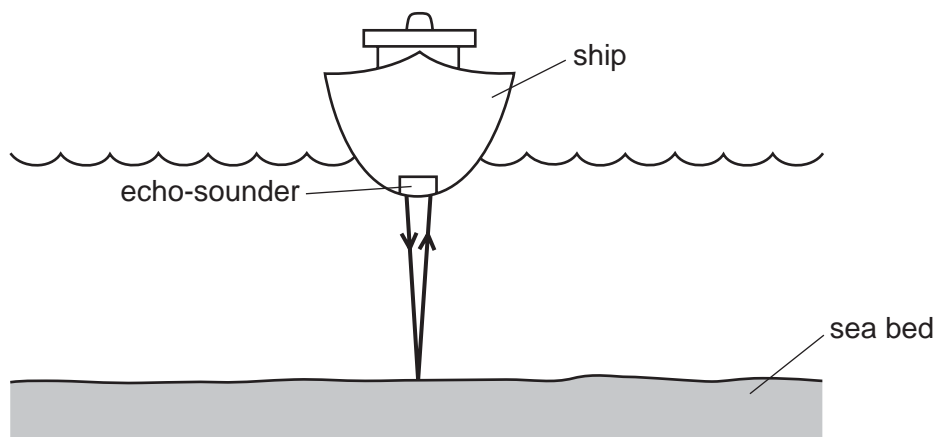

The speed of sound in sea-water is 1500 m/s .

What is the depth of the sea-water below the ship?

- A** 750 m **B** 1500 m **C** 3000 m **D** 6000 m